



Cast steel bellow sealed globe valves flanged PN 25



Art. 725

Flanges: UNI EN 1092-2 PN 25

Design: EN 1074

Face to face length: EN 558-1 serie 1

Installation: horizontal with the flow following the direction of the arrow.

APPLICATIONS • Diathermic oils • Steam • Overheated water • Oil & refineries • Industry

The cast steel globe valves with bellows do not need any maintenance. The bellow in stainless steel 304 avoids any contact between the fluid and the stem, for this reason the valves are free from maintenance. The bellow is granted for 8000 movements. The bellow sealed globe valves are suitable for severe services, such as diathermic oils, steam and flammable fluids.

Materials

body	cast steel GS-C 25, GP-240-GH
bonnet	cast steel GS-C 25, GP-240-GH
handwheel	steel
stem	stainless steel X 20 CR 13
bellow	stainless steel 304
body and disc seat facing	stainless steel 304
disc	steel
packing	graphited
bonnet gasket	graphited
painting	nitro enamel

Dimensions

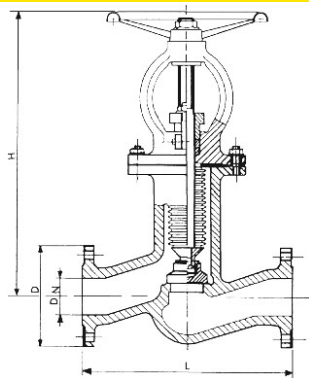

DN	L mm.	H mm.	D mm.	Weight kg.
15	130	270	95	3.7
20	150	270	105	4.3
25	160	285	115	4.7
32	180	290	140	11
40	200	310	150	12.3
50	230	320	165	18
65	290	410	185	30
80	310	425	200	36
100	350	530	235	51
125	400	550	270	63
150	480	590	300	86
200	600	720	370	175
250	730	790	450	250
300	850	830	515	320

Pressure

DN	Nominal pressure	Test pressure MPa	Max working pressure MPa
mm	BAR	body	seat
120°C	400°C		
15 - 300	25	4,0	2,75
		2,5	1,3

