



Ductile iron "Y" strainer, PN 16



Art. 416D

Perforation DN 25/80 0,8mm, DN 100/200 1,0mm, DN 250/400 1,6mm.

Flanges: UNI EN 1092-2 PN 16

Face to face: EN 558-1 serie 1, DIN 3202 F1

Installation: following the flow direction. In case of vertical installation, with flow top down.

APPLICATIONS ° Water supply ° Drinking water ° Waste water treatment plants ° industry

The "Y" strainers, made of ductile iron, are suitable to retain and collect any impurity from the pipeline. The basket screen, manufactured in stainless steel 304, is removable for its cleaning, thanks to a plug on the cover.

- Fig. 416: body in cast iron GG25

- Fig. 416A: body in stainless steel CF8M, screen in stainless steel 316

Epoxy painting suitable for drinking water applications.

Materials

body	ductile iron GGG50. EN-GJS-500
cover	ductile iron GGG50. EN-GJS-500
basket	stainless steel 304
gasket	asbestos free
painting	epoxy 250 mcr

## Dimensions

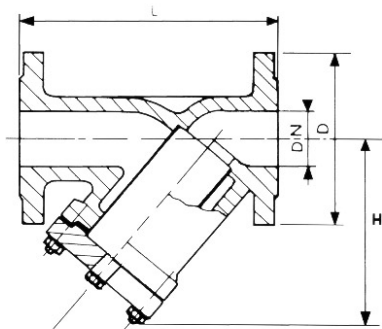

DN	L mm.	H mm.	D mm.	Weight kg.
15	130	70	95	2.5
20	150	70	105	3.5
25	160	86	115	4.5
32	180	102	140	6.5
40	200	108	150	7.5
50	230	118	165	8.3
65	290	141	185	17
80	310	160	200	20
100	350	190	220	25
125	400	223	250	37.5
150	480	295	285	56
200	600	368	340	98
250	730	515	405	139.5
300	850	560	460	208.5
350	980	620	520	250
400	1100	710	580	310
450	1200	1100	640	480
500	1250	1230	715	580
600	1450	1500	840	694
700	1650	1640	910	970
800	1850	1750	1025	1200
900	2050	1845	1125	2000
1000	2250	2000	1255	2200

## Pressure

DN	Nominal pressure		Test pressure Mpa		Max working pressure Mpa	
mm	BAR	body	seat	120°C	200°C	
15 - 400	16	2,4	1,76	1,6	1,3	

