



## Trunnion mounted ball valves RF ANSI class #150



Art. 30008

Max temperature: 120°C

Design & construction: API 608, API 6D

Face to face length: ASME / ANSI B16.10

Connections & dimensions: ASME / ANSI B16.5,

Flanges RF ANSI #150

Pressure & temperature: ASME / ANSI B 16.34

Test: API 598

Fire safe test: API 607 / API spec. 6FA & BS 6755 part 2

The trunnion mounted ball valves are used for oil and petrochemicals on big pipelines sizes and in case of severe conditions. Trunnion mounted ball valves are manufactured according to ANSI-API standard. The valve is operated by gear box.

### Materials

|           |                                    |
|-----------|------------------------------------|
| body      | cast steel A216WCB, GP240GH+N      |
| ball      | A 182 F304 / A216WCB               |
| seat ring | PTFE                               |
| stem      | steel A105 / A 182 F6              |
| spring    | inconel / alloy                    |
| painting  | high chlorinated polyethylene HCPE |

## Dimensions

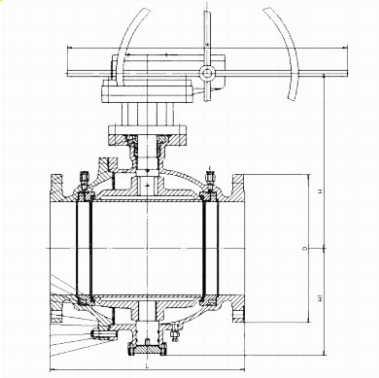

| Pressure | DN    | L mm. | H1 mm. | H mm. | D mm. | Ø W mm. |
|----------|-------|-------|--------|-------|-------|---------|
|          | 2"    | 178   | 110    | 147   | 152   | 230     |
|          | 2"1/2 | 190   | 130    | 175   | 178   | 400     |
|          | 3"    | 203   | 140    | 216   | 190   | 400     |
|          | 4"    | 229   | 160    | 250   | 229   | 700     |
|          | 5"    | 356   | 180    | 335   | 254   | 600     |
|          | 6"    | 394   | 210    | 378   | 279   | 600     |
|          | 8"    | 457   | 255    | 421   | 343   | 600     |
|          | 10"   | 533   | 310    | 482   | 406   | 600     |
|          | 12"   | 610   | 350    | 550   | 483   | 800     |
|          | 14"   | 686   | 390    | 582   | 533   | 800     |
|          | 16"   | 762   | 440    | 687   | 597   | 800     |
|          | 18"   | 864   | 480    | 730   | 635   | 800     |
|          | 20"   | 914   | 540    | 772   | 699   | 800     |
|          | 24"   | 1067  | 640    | 948   | 813   | 800     |

### Hydrostatic test

### Pneumatic test

| shell |      | seat |      | Pneumatic test |      |
|-------|------|------|------|----------------|------|
| bars  | psig | bars | psig | bars           | psig |
| 30    | 435  | 23   | 335  | 5,6            | 80   |

