



Cast steel globe valves flanged RF ANSI class # 300



Art. 1602

Design & construction: API 600, API 6D
 Face to face length: ASME / ANSI B16.10
 Connections & dimensions: ASME / ANSI B16.5, ASME / ANSI B 16.25
 Flanges: RF ANSI #300
 Pressure & temperature: ASME / ANSI B16.34
 Test: API 598

The cast steel globe valves are manufactured according to API, ANSI, ASME standard, for industrial applications. The cast steel globe valves have: outside screw and yoke, bolted bonnet, rising stem with top sealing. Standard materials are A216WCB/F6, other materials and other trims are available upon request. Handwheel operated, with reducing gear upon request.

Materials

body-bonnet	cast steel A216WCB, GP240GH+N
stem	A 182 F6
body seat facing	A182 F6
disc seat facing	A182 F6
stem packing	graphite
gasket	graphite
painting	high chlorinated polyethylene HCPE

Dimensions

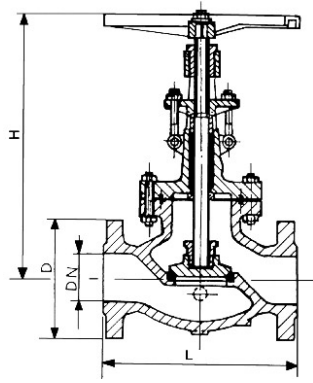

DN	L mm.	H mm.	D mm.	Weight kg.
2"	267	280	165	29
3"	318	400	210	54
4"	356	460	254	74
6"	445	620	318	145
8"	559	710	381	210
10"	622	790	444	369
12"	711	880	521	474
14"	838	1200	584	650
16"	864	1400	648	850

Pressure

Hydrostatic test

Pneumatic test

shell		seat		Pneumatic test	
bars	psig	bars	psig	bars	psig
78	1130	58	840	5,6	80

